

CRUSHER

CITY CRUSHER



680 mm x 400 mm
(27" x 16")



70 kW
380 V
50/60 Hz



Up to 80 tph
90 US tph



9,000 kg
21,000 lb



20 mm to 80 mm
3/4" to 3-1/4"

WORKING

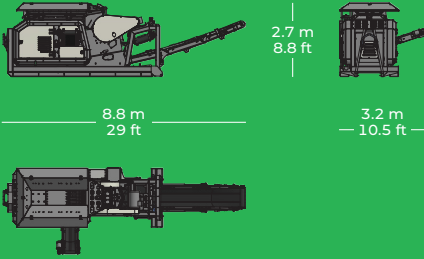

TRANSPORT

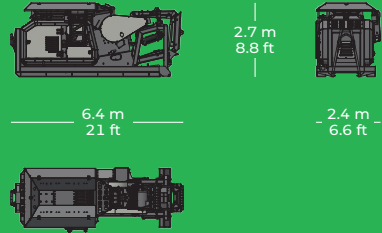

FEATURES AND BENEFITS

- Compact size for versatility, maneuverability and ease of transport.
- Quick set-up time.
- Hydraulically adjustable jaw setting.
- Direct drive crusher.
- Reverse jaw function for sticky applications / clearing blockage.
- Chamber level sensor.
- Excellent access to power pack
- Magnet raises hydraulically for clearance
- Reversible jaw plates (2 "lives").
- Easy & Intuitive Buttons Operation.
- Access Platform.
- Remote monitoring system Komplet-connect.



Komplet S.p.a.

Via Antonelli, 49 60012 Trecastelli (AN) Italy

✉ info@komplet.it

☎ +39 071 6609823

VAT 02035890421



DATA SHEET



CRUSHER

K-JC 503



500 x 300 mm
19 x 10 inch



Up to 30 tph
34 US tph



20 to 80 mm
3/4 to 3-1/4 inch



Stage V 18.5 kW
25 Hp Diesel

Tier 4F 18.5 kW
25 Hp Diesel

Stage 3A 21.5 kW
28 Hp Diesel



3,400 kg
7,496 lb

Komplet.it

WORKING AND TRANSPORT

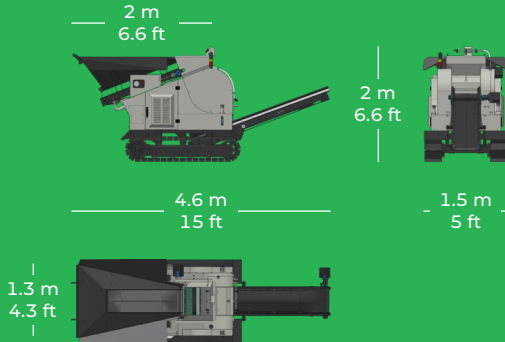

TRANSPORT OPTION

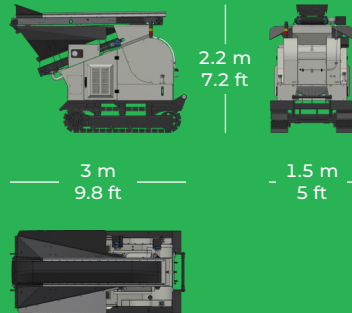

FEATURES AND BENEFITS

- Quick set-up time typically under 15 minutes.
- Hydraulic jaw adjustment.
- Available as rubber track or trailer EU versions.
- Variable speed hopper.
- Remote control for all function.
- Reversible jaw plates (2 “plates”).
- Direct drive chamber.



Komplet S.p.a.

Via Antonelli, 49 60012 Trecastelli (AN) Italy

✉ info@komplet.it

☎ +39 071 6609823

VAT 02035890421





LEM4825

TECHNICAL SPECIFICATION

LEM4825

The LEM 4825 mini crusher is a reliable stationary jaw crusher. Powered by an electric motor, it is easy to carry and operate. For a fact, it is a “plug and play” machine: simply connecting the power plug to the power line makes it immediately ready to use. The Komplet LEM 4825 crusher is an affordable solution with a high production rate, it is suitable for both small and medium-sized companies that do not want to invest too much time and resources for the recovery and recycling of building material.

1. CRUSHER
2. FEEDER
3. PRODUCT CONVEYOR
4. CONTROL SYSTEM



CRUSHER

TECHNICAL DATA

JAW CRUSHER

Crusher dimension
480x250 mm

Jaw adjustment
Hydraulic

Granulometry
15-80 mm

FEEDING: BELT WITH HOPPER

Length
2500 mm

Width
500 mm

Hopper Capacity
0,5 m³

Loading Height
2000 mm

EXTRACTING BELT

Length
4000 mm

Width
400 mm

Pile height
1750 mm

CRUSHER ELECTRIC MOTOR

Power
7,5 kW

Power supply
380/50-60 V/Hz

Pick up
15/18 kW

PERFORMANCE

Production
5-30 T/h

Max size
300 mm

Standard weight
2100 kg



ELECTRIC PANEL

Complete with all controls placed on board.

ACCESSORIES

- Magnetic roller.
- Dust dumping system.

TRANSPORT DIMENSION

Length 4000 mm
 Width 1270 mm
 Height 2500 mm

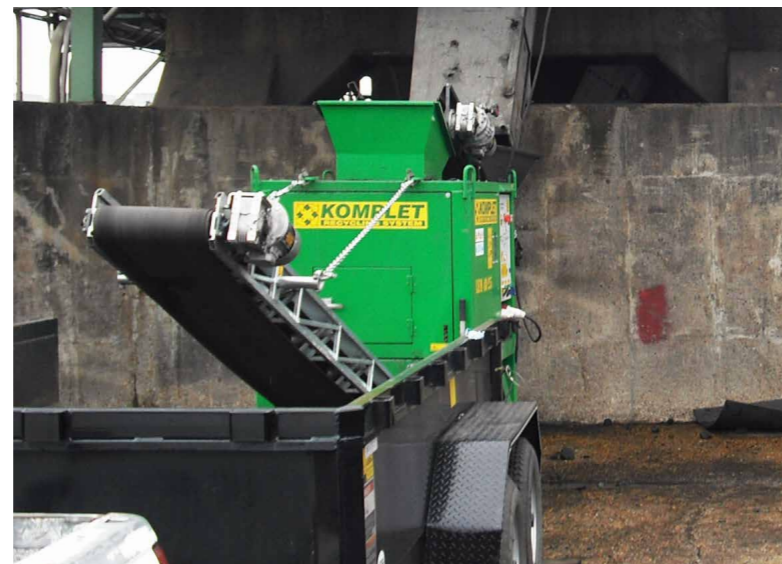

TRANSPORT DIMENSION & WORKING DIMENSION

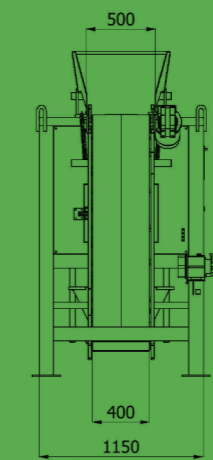
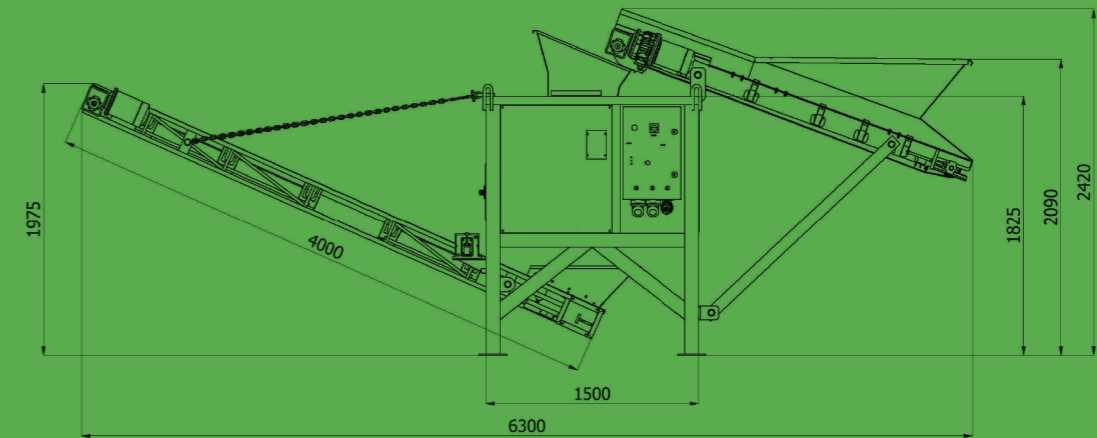



DATA SHEET



CRUSHER

K-JC 704



680 mm x 400 mm
(27" x 16")



Up to 80 tph
90 US tph



20 mm to 80 mm
3/4" to 3-1/4"



Stage V 55 kW
74 Hp Diesel

Tier 4F 55 kW
74 Hp Diesel

Stage 3A 61 kW
83 Hp Diesel



12,000 kg
26,455 lb

Komplet.it

WORKING

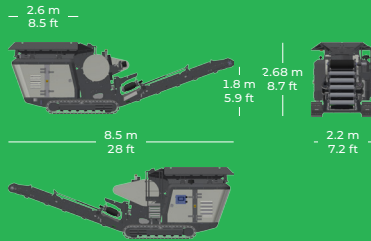

TRANSPORT CONTAINER

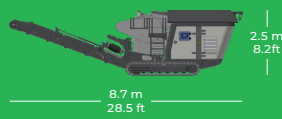

TRANSPORT TRUCK

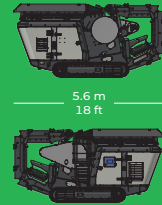

FEATURES AND BENEFITS

- Compact size for versatility, maneuverability and ease of transport.
- Quick set-up time.
- Hydraulically adjustable jaw setting.
- Direct drive crusher.
- Reverse jaw function for sticky applications / clearing blockage.
- Chamber level sensor.
- Excellent access to power pack.
- Magnet raises hydraulically for clearance.
- Reversible jaw plates (2 “lives”).
- Easy & Intuitive Buttons Operation.
- Access Platform.
- Remote monitoring system Komplet-connect.



Komplet S.p.a.

Via Antonelli, 49 60012 Trecastelli (AN) Italy

✉ info@komplet.it

☎ +39 071 6609823

VAT 02035890421



DATA SHEET



CRUSHER

K-JC 805



815 mm x 520 mm
(31" x 21")



Up to 140 tph
160 US tph



30 mm to 120 mm



Stage V 100 kW
130 Hp Diesel

Tier 4F 100 kW
130 Hp Diesel

Stage 3A 100 kW
130 Hp Diesel



22,500 kg
49,600 lb

Komplet.it

WORKING

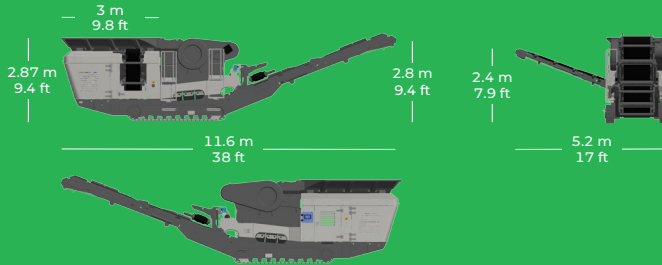

TRANSPORT

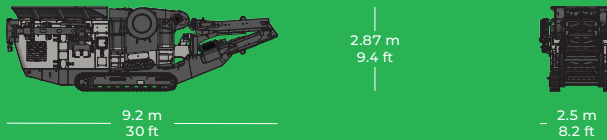

FEATURES AND BENEFITS

- Compact size for versatility, maneuverability and ease of transport.
- Hydraulically adjustable jaw setting.
- No stop Crushing by hydraulic release patent pending.
- Reverse jaw function for sticky applications/clearing blockage.
- Direct drive crusher with excellent access to drive belts and hydraulics.
- Vibrating feeder with load sensor.
- Magnet raises hydraulically for clearance.
- Easy & Intuitive Buttons Operation.
- Access Platform + Open chassis design for ease of maintenance.
- Integrated hydraulic folding stockpiling conveyors.
- Remote monitoring system Komplet-connect.
- Fit into a 40ft container.
- Deflector plate under the crusher.
- Automatic wear recovery to adjust the correct CSS that has been set.
- Side dirty belt.



Komplet S.p.a.

Via Antonelli, 49 60012 Trecastelli (AN) Italy

✉ info@komplet.it

☎ +39 071 6609823

VAT 02035890421



DATA SHEET



SCREENER

KOMPATTO 104



1. 3,015x1,240 mm
8x4 inch
2. 3,015x1,240 mm
8x4 inch



- | | |
|----------|-----------------------|
| Stage V | 35 kW
45 Hp Diesel |
| Tier 4F | 35 kW
45 Hp Diesel |
| Stage 3A | 36 kW
47 Hp Diesel |



Up to 200 tph
220 US tph



8,000 kg
17,636 lb

Komplet.it

WORKING

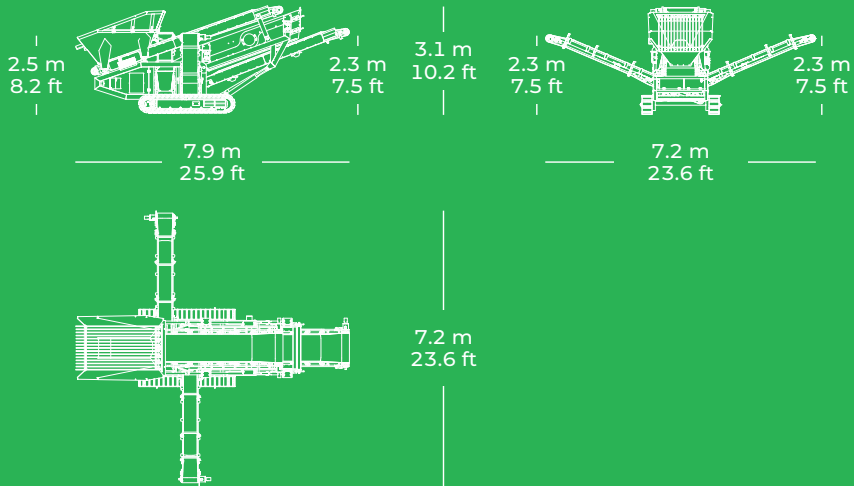

FEATURES AND BENEFITS

- High capacity up to 200 tph / 220 US tph (depending on feed size, mesh & material type)
- Quick set-up
- Hydraulically folding conveyors
- Fit into the 40ft container
- Smart design minimised weight 8 ton
- Variable speed feeder
- Removable grid for screening before crusher
- Designed for a wide range of materials and aggregates



Komplet S.p.a.

Via Antonelli, 49 60012 Trecastelli (AN) Italy

✉ info@komplet.it

☎ +39 071 6609823

VAT 02035890421



DATA SHEET



SCREENER

KOMPATTO 5030



1. 2,450x970 mm
10x4 inch
2. 2,190x970 mm
10x4 inch



- | | |
|----------|-----------------------|
| Stage V | 35 kW
45 Hp Diesel |
| Tier 4F | 35 kW
45 Hp Diesel |
| Stage 3A | 36 kW
47 Hp Diesel |



Up to 250 tph
280 US tph



12,000 kg
26,455 lb

[Komplet.it](https://www.komplet.it)

WORKING

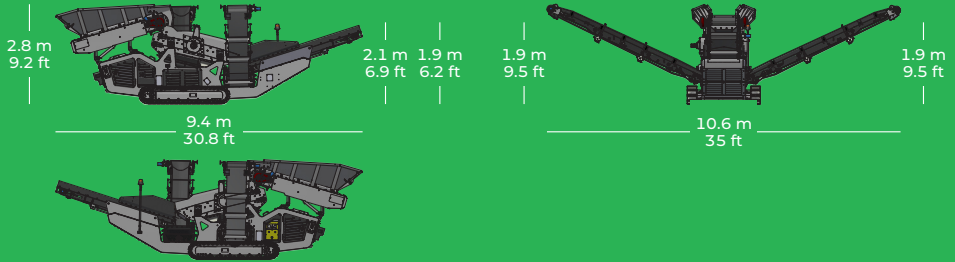

TRANSPORT



FEATURES AND BENEFITS

- Heavy duty single shaft incline screenbox with adjustable stroke & speed.
- Quick set-up time.
- Hydraulically folding conveyors.
- Fit into 40ft container.
- Smart design minimized weight 12ton.
- Rapid conversion from 3 way split to 2way split (fully hydraulic).
- Variable speed hopper.
- Versatile unit for three way splitting, stockpiling or scalping before or after a crusher.



Komplet S.p.a.

Via Antonelli, 49 60012 Trecastelli (AN) Italy

✉ info@komplet.it

☎ +39 071 6609823

VAT 02035890421



DATA SHEET



SCREENER

KOMPATTO 221



1. 2,100x1,085 mm
8x4 inch
2. 2,100x1,085 mm
8x4 inch



- | | |
|----------|--------------|
| Stage V | 18.5 kW |
| | 25 Hp Diesel |
| Tier 4F | 18.5 kW |
| | 25 Hp Diesel |
| Stage 3A | 21.5 kW |
| | 28 Hp Diesel |



Up to 30 tph
34 US tph



3,300 kg
7,275 lb

Komplet.it

WORKING AND TRANSPORT OPTION LONG FINE BELT

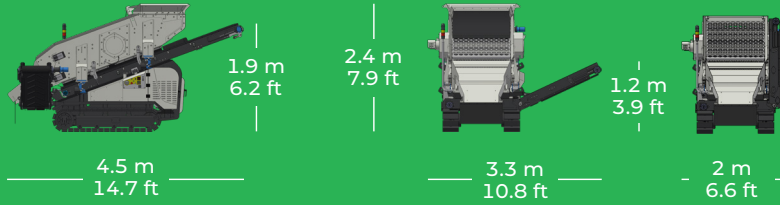

TRANSPORT OPTION SHORT FINE BELT

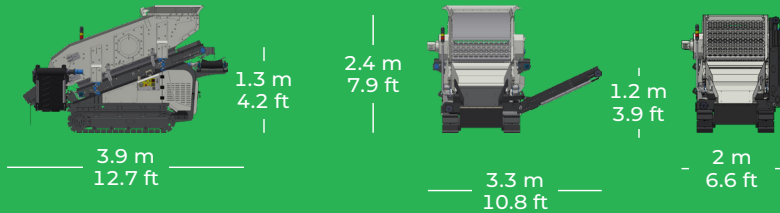

FEATURES AND BENEFITS

- High capacity up to 30 tph / 34 us tph (depending on feed size, mesh & material type).
- Direct feed onto pan area.
- Choice of screen meshes/punch/arpa/anticlogging.
- Quick setp.
- Remote control.
- Hydraulically folding conveyors.
- End tension screen.
- Fit into the 20ft container.
- Smart design minimised weight 3.2 ton.



Komplet S.p.a.

Via Antonelli, 49 60012 Trecastelli (AN) Italy

✉ info@komplet.it

☎ +39 071 6609823

VAT 02035890421





WV2080

TECHNICAL SPECIFICATION

WV2080

The Komplet WV series screens are practical, lightweight, affordable, easy to use and to transport. They are a must have equipment for all the small and medium-size contractors, needing to select and sort material for their own reuse. Perfect for small treatment plants as rubble and soil remediation, in combination with Komplet crushers like LEM4825 and M5000.

- 1. SCREENBOX
- 2. FRAME
- 3. POWERUNIT
- 4. CONTROLSYSTEM

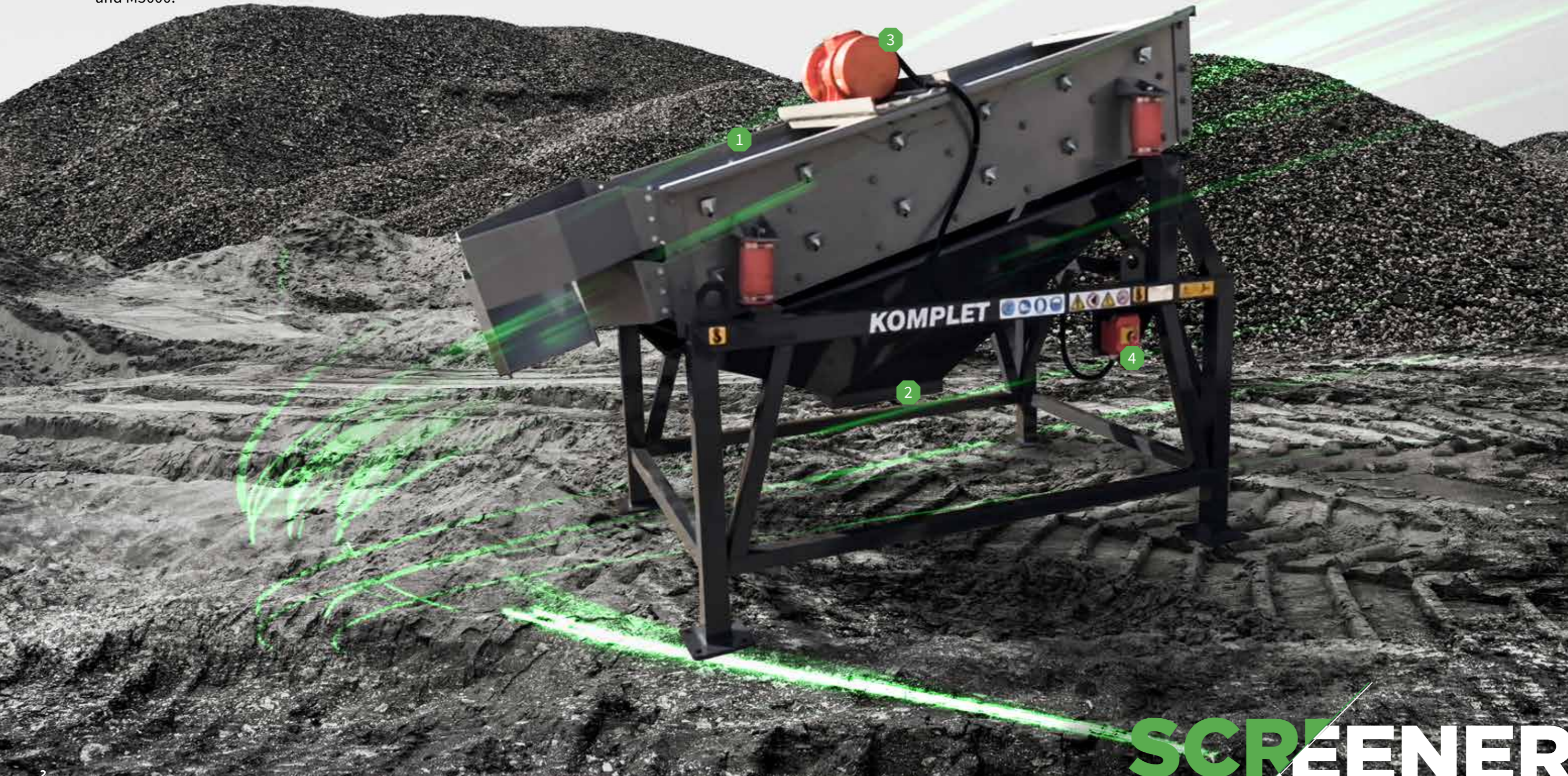

TECHNICAL DATA

VIBRATING SCREEN

Grid Dimensions
2000x800 mm

Screening Grid
N° 01-02

PERFORMANCE

Production
10-40 T/h

Max size
0-100 mm

Standard weight
520 kg

Electric Power
1,1/380 kW/V



TRANSPORT DIMENSION & WORKING DIMENSION

